

CrystaLatch™ 1x1,1x2, Solid-State Fiberoptic Switch

(Protected by U.S. patents 7224860, 6757101, 6577430 and pending patents)

Product Description

The CL Series 1x1 and 1x2 solid-state fiber optical switch connects optical channels by redirecting an incoming optical signal into a selected output fiber. This is achieved using patented non-mechanical configurations and activated via an electrical control signal. Latching operation preserves the selected optical path after the drive signal has been removed. The all solid state CL 1x1,1x2 fiberoptic switch features low insertion loss, high extinction ratio, high channel isolation, and extremely high reliability and repeatability. It is designed to meet the most demanding switching requirements of continuous operation without failure, longevity, operation under shock/vibration environment and large temperature variations, and fast response time.

The switch also has build-in circulator and isolator functions. Electronic driver is available for this series of switches.



Performance Specifications

CL Series 1x1,1x2 Switch	Min	Typical	Max	Unit
Operation Wavelength ¹	1520	1550	1580	nm
	1295	1310	1325	nm
Insertion Loss ²		0.7	1.0	dB
Cross Talk ³	40	50		dB
Switch Speed (rise, fall)	20	50	200	μs
Repetition Rate		5K		Hz
Polarization Dependent Loss		0.1	0.2	dB
Polarization Mode Dispersion		0.1	0.2	ps
Return Loss	50	55		dB
Operating Temperature ⁵	-5		70	°C
Optical Power Handling ⁴		300	500	mW
Storage Temperature	-40		85	°C
Fiber Type	Corning SMF-28			
Package Dimension	58.2L x 8.4W x 8.4H			mm

1. Agiltron can achieve same SPEC at L band
2. Measured without connectors
3. The typical crosstalk of single stage is 20dB
4. High power version available.
5. -40 °C version is also available.

Features

- Solid-State high speed
- Ultra-high reliability
- Fail-safe latching
- Low insertion loss
- Direct low voltage drive
- Compact
- Low cost

Applications

- Optical channel blocking
- Configurable Add/Drop
- System monitoring
- Instrumentation

CrystaLatch™

1x1, 1x2 Solid-State Fiberoptic Switch

Electrical Driving Information

The switch is actuated by applying a voltage pulse. Applying one polarity pulse, one light path will be connected and latched to the position. Applying a reversed polarity pulse, another light path will be connected and latched to the position after pulse removed.

Parameter	Minimum	Typical	Maximum	Unit
Drive Voltage	4.5	5	6	V
Drive Current	110	140	195	mA
Pulse Duration	0.2	0.5	10	ms

Driving kit with RS232 and TTL interfaces and Windows™ GUI is available

CL 1x2 Switch

Optical Path	Pin 1	Pin 2
Port 1→Port 2	GND	5V Pulse
Port 1→Port 3	5V Pulse	GND

CL 2x1 Switch

Optical Path	Pin 1	Pin 2
Port 2→Port 1	5V Pulse	GND
Port 3→Port 1	GND	5V Pulse

Mechanical Dimensions (mm)

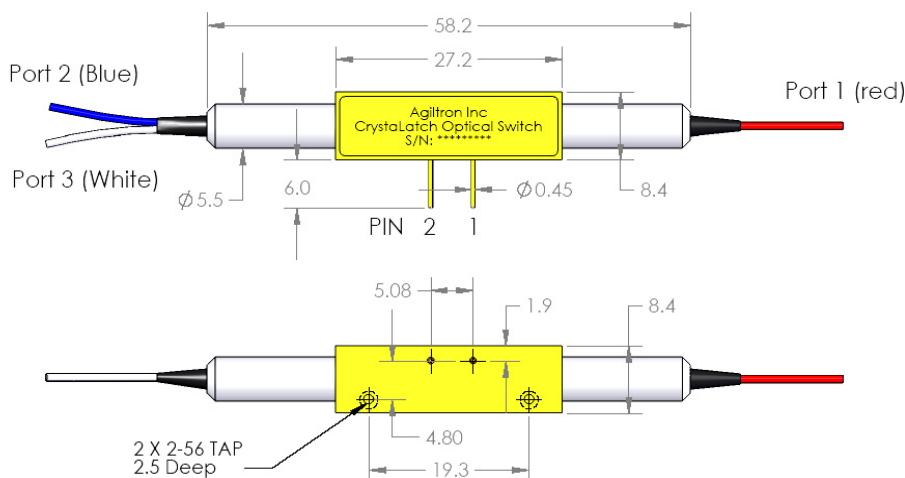

Ordering Information

CLSW-	Type	Wavelength	Switch	Package	Fiber Type	Fiber Length	Connector
<input type="checkbox"/> <input type="checkbox"/> <input type="checkbox"/> <input type="checkbox"/> <input checked="" type="checkbox"/> <input type="checkbox"/> <input type="checkbox"/> <input type="checkbox"/>	1x1=11 1x2=12 2x1=21	1310=3 1550=5 Special=0	Dual Stage=2	Special = 0	SMF-28 =1 Special=0 Bare fiber=1 900um loose tube=3 Special = 0	0.25m=1 0.5m=2 1.0m=3 Special=0	None = 1 FC/PC = 2 FC/APC = 3 SC/PC = 4 SC/APC = 5 ST/PC = 6 LC = 7 Special = 0