

CrystaLatch™ 1x8 Fiberoptic Switch

(Protected by U.S. patents 7224860, 6757101, 6577430 and pending patents)

Product Description

The CL Series 1x8 fiber optical switch connects optical channels by redirecting an incoming optical signal into a selected output fiber. This is achieved using patented non-mechanical configurations and activated via an electrical control signal. Latching operation preserves the selected optical path after the drive signal has been removed. The all solid state CL 1x8 fiberoptic switch features low insertion loss, high extinction ratio, high channel isolation, and extremely high reliability and repeatability. It is designed to meet the most demanding switching requirements of continuous operation without failure, longevity, operation under shock/vibration environment and large temperature variations, and fast response time.

The switch also has build-in Circulator and isolator functions. Electronic driver is available for this series of switches.



Performance Specifications

CL Series 1x8 Switch	Min	Typical	Max	Unit
Operation Wavelength ¹	1520	1550	1580	nm
	1295	1310	1325	nm
Insertion Loss ²		1.3	2.5	dB
Uniformity		0.7	1.0	dB
Cross Talk ³	36	50		dB
Switch Speed (Rise, Fall)	20	50	200	µs
Repetition Rate			5K	Hz
Polarization Dependent Loss		0.15	0.4	dB
Polarization Mode Dispersion			0.2	ps
Return Loss ²	50			dB
Operating Temperature ⁵	-5		65	°C
Optical Power Handling ⁴		300	500	mW
Storage Temperature	-40		85	°C
Switch type	Solid-State Latching			
Fiber Type	Corning SMF28			
Package Dimension	82.8L x 37.3W x 8.5H			mm

1. Agiltron can achieve same SPEC at L band
2. Measured without connectors
3. The typical crosstalk of single stage is 20dB
4. High power version available.
5. -40 °C version is also available.

15 Cabot Road, Woburn, MA 01801 Tel: (781) 9351200 Fax: (781) 935-2040

www.agiltron.com

Features

- High Speed
- Non-Mechanical
- High Reliability
- Fail-Safe Latching
- Low Insertion Loss
- Rugged
- Compact
- Cost Effective
- Direct Low Voltage Drive

Applications

- Optical Signal Routing
- Network Protection
- Burst Switching
- Configurable Add/Drop
- Signal Monitoring
- Instrumentation

CrystaLatch™

1x8 Fiberoptic Switch

Electrical Driving Information

Each switching point is actuated by applying a voltage pulse. Applying one polarity pulse, one light path will be connected and latched to the position. Applying a reversed polarity pulse, another light path will be connected and latched to the position after pulse removed.

Parameter	Minimum	Typical	Maximum	Unit
Resistance (each group)	15	18	22	Ω
Switch Voltage	2.5		3	V
Pulse Duration	0.1	0.2	2	ms

Driving kit with RS232 and TTL interfaces and Windows™ GUI is available.

Electric Driving Table

Optical Path	Pin Group 1		Pin Group 2		Pin Group 3		Pin Group 4		Pin Group 5		Pin Group 6		Pin Group 7		Pin Group 8	
	1	2	3	4	5	6	7	8	9	10	11	12	13	14	15	16
Input- Output 1	+	-	+	-	-	+	-	+	+	-	+	-	-	+	+	-
Input- Output 2	-	+	-	+	-	+	-	+	+	+	-	-	-	+	+	-
Input- Output 3	+	-	-	+	-	+	-	+	+	-	+	-	+	-	-	+
Input- Output 4	-	+	+	-	-	+	-	+	+	-	+	-	+	-	-	+
Input- Output 5	+	-	-	+	+	-	+	-	+	-	-	+	-	+	-	+
Input- Output 6	-	+	+	-	+	-	+	-	+	-	-	+	-	+	-	+
Input- Output 7	+	-	-	+	+	-	-	+	-	+	+	-	-	+	-	+
Input- Output 8	-	+	+	-	+	-	-	+	-	+	+	-	-	+	-	+

“+”: 2.5~3.0V Pulse; “-”: Ground.

Mechanical Dimensions (Unit:mm)

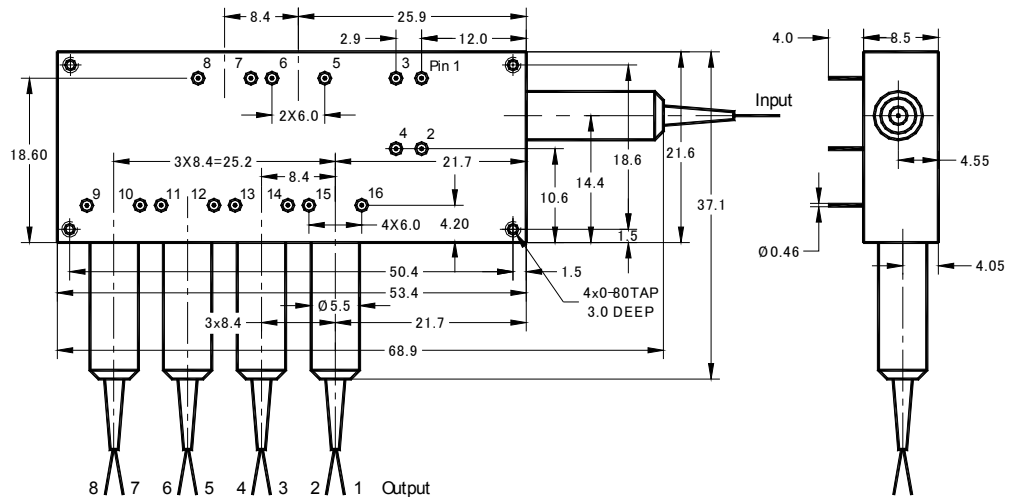

CrystaLatch™

1x8 Fiberoptic Switch

Ordering Information

CLSW-	<input type="checkbox"/>	<input type="checkbox"/>	<input type="checkbox"/>	<input type="checkbox"/>	<input type="checkbox"/>	<input type="checkbox"/>	<input type="checkbox"/>	<input type="checkbox"/>	
Type	Wavelength	Switch	Package	Fiber Type	Fiber Length	Connector			
1x8=18 8x1=81	1310=3 1550=5 Special=0	Dual Stage=2	Standard=2 Special=0	SMF-28 =1 Special=0	Bare fiber=1 900,µm loose tube=3 Special=0	0.25m=1 0.5m=2 1.0m=3 Special=0	None=1 FC/PC=2 FC/APC=3 SC/PC=4 SC/APC=5 ST/PC=6 LC=7 Duplex LC=8 Special=0		