



LightBend™ Mini 1x8 OptoMechanical Fiberoptic Switch

(Protected by U.S. patent 6823102 and pending patents)

Product Description

The LB Series Mini 1x8 fiber optic switch connects optical channels by redirecting an incoming optical signal into a selected output fiber. This is achieved by using a patent pending opto-mechanical configuration activated via an electrical control signal. Latching operation preserves the selected optical path after the drive signal has been removed. The switch has integrated electrical position sensors, and the new material based advanced design significantly reduces moving part position sensitivity, offering unprecedented high stability as well as an unmatched low cost.

We offer tight-bend-fiber version, which reduces the minimum bending radius from normal 15 mm to 7 mm. This feature enables smaller overall foot print.



Features

- Unmatched Low Cost
- Low Optical Distortions
- High Isolation
- High Reliability
- Epoxy-Free Optical Path

Performance Specifications

LB Series Mini 1x8 Switch	Min	Typical	Max	Unit
Operation Wavelength	Dual Band	1260-1360 and 1510-1610		nm
	Single Band	1260-1360 or 1510-1610		nm
	Broad Band	1260 ~ 1610		nm
Insertion Loss ¹	0.5	0.8	1.2	dB
Wavelength Dependent Loss		0.2	0.4	dB
Polarization Dependent Loss	0.05	0.1	0.15	dB
Return Loss	55			dB
Cross Talk	50			dB
Switching Time		3	10	ms
Repeatability			±0.05	dB
Operating Voltage	5	5	7	VDC
Voltage Pulse Width (Latching)		20		ms
Switching Type		Latching / Non-Latching		
Operating Temperature ²	-5		70	°C
Optical Power Handling		300	500	mW
Storage Temperature	-40		85	°C
Fiber Type		SMF-28		
Package Dimension		67.0L x 25.0W x 10.0H		mm

Note:

1. Exclude connectors.

Applications

- Channel Blocking
- Configurable Add/Drop
- System Monitoring
- Instrumentation





LightBend™ Mini 1x8 OptoMechanical Fiberoptic Switch

Electrical Driving Requirement

The load is a resistive coil which is activated by applying 5V (draw ~ 40mA). Applying too long pulse for the latching version will heat up the device. Agiltron offers a computer control kit with TTL and RS232 interfaces and Windows™ GUI

Latching Type

Optical Path	Relay	Electric Drive		Status Sensor			
		Pin 1	Pin 8	Pin 2-3	Pin 3-4	Pin 5-6	Pin 6-7
Input → Port 1	Relay1	5V Pulse	GND	Open	Close	Close	Open
	Relay 2, 3, 4, 5, 6, 7	N/A	N/A				
Input → Port 2	Relay 1	GND	5V Pulse	Close	Open	Open	Close
	Relay 2	5V Pulse	GND	Open	Close	Close	Open
	Relay 3, 4, 5, 6, 7	N/A	N/A				
Input → Port 3	Relay1, 2	GND	5V Pulse	Close	Open	Open	Close
	Relay 3	5V Pulse	GND	Open	Close	Close	Open
	Relay 4, 5, 6, 7	N/A	N/A				
Input → Port 4	Relay 1, 2, 3	GND	5V Pulse	Close	Open	Open	Close
	Relay 4	5V Pulse	GND	Open	Close	Close	Open
	Relay 5, 6, 7	N/A	N/A				
Input → Port 5	Relay 1, 2, 3, 4	GND	5V Pulse	Close	Open	Open	Close
	Relay 5	5V Pulse	GND	Open	Close	Close	Open
	Relay 6, 7	N/A	N/A				
Input → Port 6	Relay1, 2, 3, 4, 5	GND	5V Pulse	Close	Open	Open	Close
	Relay 6	5V Pulse	GND	Open	Close	Close	Open
	Relay 7	N/A	N/A				
Input → Port 7	Relay 1, 2, 3, 4, 5, 6	GND	5V Pulse	Close	Open	Open	Close
	Relay 7	5V Pulse	GND	Open	Close	Close	Open
Input → Port 8	Relay 1, 2, 3, 4, 5, 6, 7	GND	5V Pulse	Close	Open	Open	Close

Non-Latching Type

Optical Path	Relay	Electric Drive		Status Sensor			
		Pin 1	Pin 8	Pin 2-3	Pin 3-4	Pin 5-6	Pin 6-7
Input → Port 1	Relay 1	5V	GND	Open	Close	Close	Open
	Relay 2, 3, 4, 5, 6, 7	No Power		Close	Open	Open	Close
Input → Port 2	Relay 2	5V	GND	Open	Close	Close	Open
	Relay 1, 3, 4, 5, 6, 7	No Power		Close	Open	Open	Close
Input → Port 3	Relay 3	5V	GND	Open	Close	Close	Open
	Relay 1,2, 4, 5, 6, 7	No Power		Close	Open	Open	Close
Input → Port 4	Relay 4	5V	GND	Open	Close	Close	Open
	Relay 1, 2, 3, 5, 6, 7	No Power		Close	Open	Open	Close
Input → Port 5	Relay 5	5V	GND	Open	Close	Close	Open
	Relay 1, 2, 3, 4, 6, 7	No Power		Close	Open	Open	Close
Input → Port 6	Relay 6	5V	GND	Open	Close	Close	Open
	Relay1, 2, 3, 4, 5, 7	No Power		Close	Open	Open	Close
Input → Port 7	Relay 7	5V	GND	Open	Close	Close	Open
	Relay 1, 2, 3, 4, 5, 6	No Power		Close	Open	Open	Close
Input → Port 8	Relay 1, 2, 3, 4, 5, 6, 7	No Power		Close	Open	Open	Close

LightBend™ Mini 1x8 OptoMechanical Fiberoptic Switch

Mechanical Dimensions (Unit:mm)

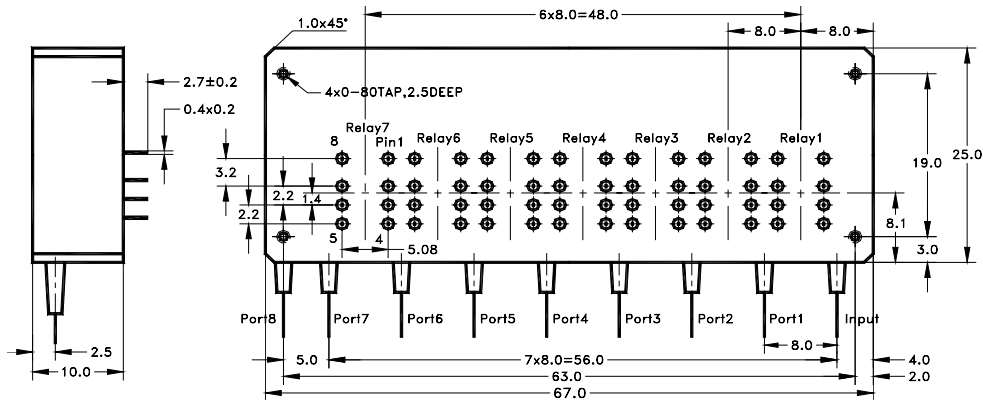

Ordering Information

LBMN-	Type	Wavelength	Switch	Package	Fiber Type	Fiber Length	Connector
<input type="checkbox"/>	1x8=18	1060=1	Latching=1	Standard=1	SMF-28 =1	Bare fiber=1	None=1
<input type="checkbox"/>	8x1=81	C+L=2	Non-latching=2	Special=0	Corning XB=2	900um tube=3	FC/PC=2
<input type="checkbox"/>	Special=00	1310=3	Special=0		Draka BBE=3	Special=0	FC/APC=3
		1410=4			Special=0		SC/PC=4
		1550=5					SC/APC=5
		650=6					ST/PC=6
		780=7					LC=7
		850=8					Duplex LC=8
		1310 & 1550=9					Special= 0
		Special=0					