

Manual PM Fiber Optic Tunable Filter

(patent pending)

Product Description

Based on a proprietary thin film cavity filter technology, Agiltron offers PM Fiber Optic Tunable Filter with central wavelengths ranging from 450 nm to 2000 nm. It is tunable continuously over a wide spectral range up to 80 nm. Agiltron further offers high optical power handling up to 10 W(CW) while maintaining the transmission spectral shape polarization-insensitive over the whole tuning range. Agiltron's unique high reliability and low insertion loss design presents a most cost-effective solution for OEM applications from fiber optic networks to fiber sensing interrogation.



Features

- Compact and Low Cost
- High Power Handling
- Wide Tune Range
- Wide Wavelength Coverage
- Low IL, PDL & WDL

Performance Specifications

PM Fiber Optic Tunable Filter	Min	Typical	Max	Unit
Central Wavelength*	-	1060, 1310 or 1550	-	nm
Tuning Range	-	40	80	nm
Tuning Resolution	0.02	0.1	-	nm
Insertion Loss	2	3	4	dB
Bandwidth @-3dB	-	1	1.2	nm
Bandwidth @-20dB	-	10	-	nm
Extinction @ 10 nm Deviation	-	30	-	dB
Extinction Ration	18	23	-	dB
Return Loss	40	-	-	dB
Max. Input Optical Power (CW)	-	1	10	W
Operating Temperature	0	20	70	° C
Size	-	104x43x20	-	mm

Note: * Other wavelengths are available

Applications

- DWDM networks
- Fiber Sensing
- ASE control
- Tunable Fiber Laser sources

Manual PM Fiber Optic Tunable Filter

Mechanical Dimensions (Unit: mm)

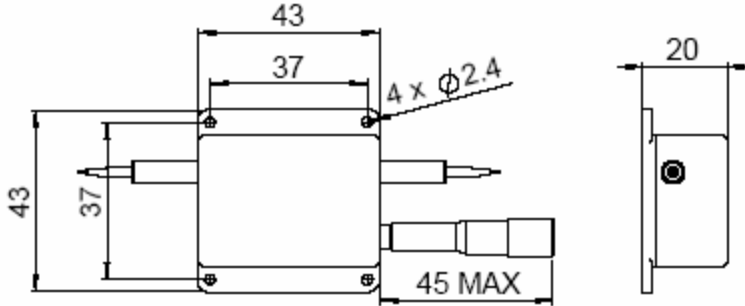

Typical Transmission Curve

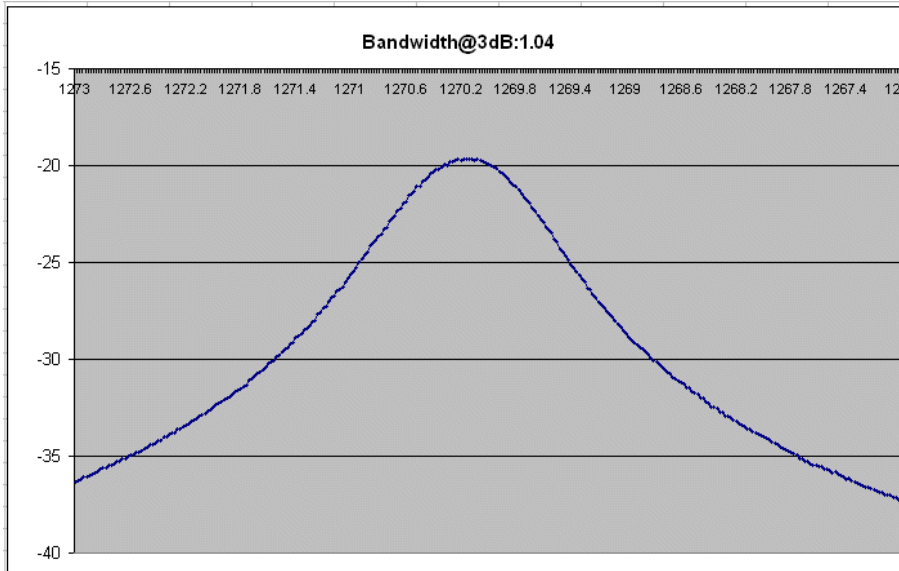

Ordering Information

FOTF-	0 2	<input type="checkbox"/>	1	2	<input type="checkbox"/>	<input type="checkbox"/>	<input type="checkbox"/>	<input type="checkbox"/>
	Type	Wavelength	Config.	Package	Fiber Type	Fiber Length	Connector	
		1310 = 3 1550 = 5 1060 = 6 Special = 0			Panda PM Fiber 400 = 4 Panda PM Fiber 250 = 5 Special = 0	Bare fiber = 1 900um loose tube = 3 Special = 0	0.25m = 1 0.5m = 2 1.0m = 3 Special = 0	None = 1 FC/PC = 2 FC/APC = 3 SC/PC = 4 SC/APC = 5 ST/PC = 6 LC = 7 Special = 0