

NanoSpeed™ Two-Stage Variable Optical Attenuator/ Modulator

(protected by US patent 7,403,677 and pending patents)

Product Description

The NS variable fiber optic attenuator is an electro-optic device that provides electrical control of optical power. This is achieved using a patented non-mechanical configuration and activated via an electrical control signal. The solid-state optical crystal design eliminates mechanical movement and organic materials. The NS series variable optical attenuators are designed to meet the most demanding operation requirements of ultra-high reliability and fast response time with minimum mechanical footprint. Agiltron also offers customized electronic designs to meet special control requirements and applications.

The dual stage version provides deep attenuation with normally-opaque and normally-transparent configurations. The device comes with an electronic driving daughter board with 5 V input voltage and 0-5 V control signal.

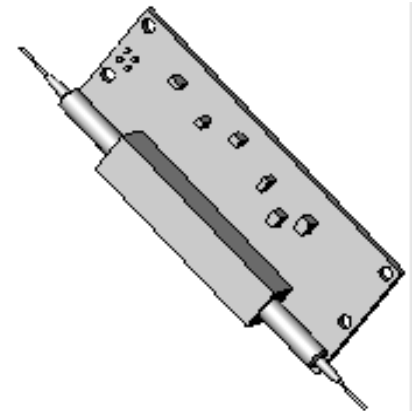

Performance Specifications

NS Two-Stage Attenuator	Min	Typical	Max	Unit
Wavelength		1550		nm
Insertion Loss		0.8	1.5	dB
Polarization Dependent Loss		0.1	0.35	dB
Return Loss	45	50		dB
Attenuation Range	45			dB
Response Time (Rise, Fall)			500	ns
Repetition Rate	DC		5	KHz
Resolution		Continuous		dB
Operating Optical Power			500	mW
Operating Temperature		-5 ~ 70		°C
Storage Temperature		-40 ~ 85		°C
Package Dimension		77X30X11		mm

* Driver kit is recommended

Features

- No Moving Parts
- High Reliability
- Solid-State High Speed
- Low Insertion Loss
- Epoxy-Free Optical Path
- Low Power Consumption
- Simple Driver

Applications

- Power Control
- Power Regulation
- Power Balance
- Instrumentation



